

Paddle flow switches, reed switch contact, external brass body. Type: R1V

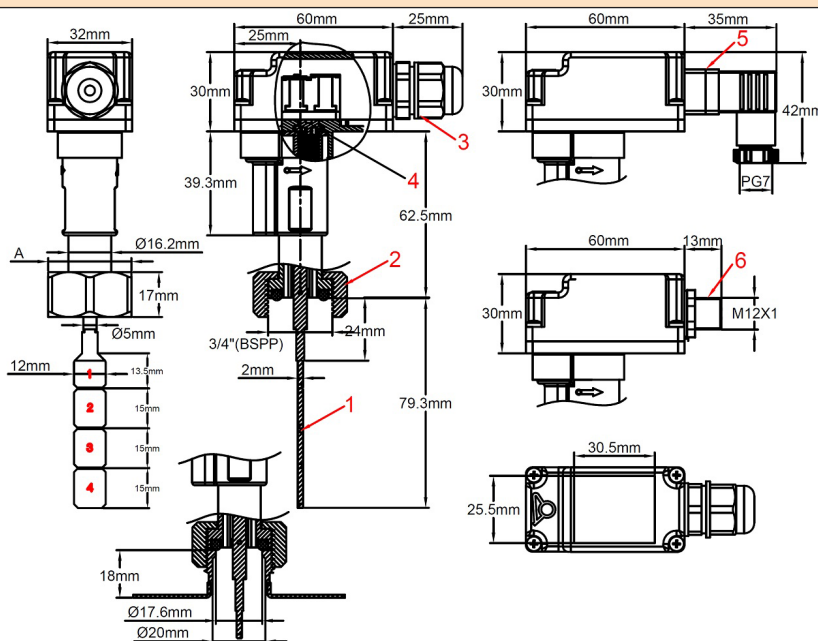

Because of permanent improvement of our products, drawings, descriptions, features used on these data sheets are for guidance only and can be modified without prior advice

Size and pressure	Flow sensing: Cleavable paddle	Mounting: 3/4" BSPP brass union nut	Contact: Reed switch, close on flow rise	Electrical rating	Mounting position	Type
PN25 DN≥15				≤1A ≤70W ≤250V~		R1V



- 1: Paddle
- 2: 3/4" BSPP Brass union nut and brass body
- 3: Connection box
- 4: Adjustment screw
- 5: EN17530-803-A (DIN43650-A) connector (Option)
- 6: IEC947-5-2, M12×1, 4 terminals connector (Option)

Main uses: General application in flow detection. Recommended mounting position is on horizontal pipes, but can be mounted in any position. For liquids flow detection on **dia. 15 to 100mm** pipes. **Body and union nut in brass for improved mechanical strength and pressure resistance. Connection box with terminal block or connectors, and detection point adjustment screw**

Functional principle: Balanced magnetic pallet mounted perpendicular to the flow and activating a reed switch through the wall. The return of the pallet is by made by magnetic action, without spring. No seal or liquid can pass between the piping system and the electrical contact. Usable for industrial applications in non-corrosive liquids. Must not be used for liquids containing magnetic particles or high viscosity liquids, which block the movement of the pallet.

Adjustment:

- By cleaving the paddle
- Fine adjustment by screw driver on internal dial

Paddle shaft: **Titanium**, providing an outstanding corrosion resistance, and improved mechanical live

Main housing material: Brass

Paddle: Polypropylene, 15 mm width, with 4 sections, numbered 1 to 4, can be cleaved for adjustment to pipe size

Pipe mounting: Nickel plated brass union nut, 3/4" BSPP, mounting on 3/4" BSPP male thread with gasket. Recommended torque: 10±1Nm

Gasket: NBR

Electrical rating: Max 1A, Max 70W, Max 250V, resistive load. Use on inductive circuits reduces electrical rating. We recommend to protect the reed switch with contact protection device when used in inductive loads

Electric contact type: Normally open, closes by flow rise

Liquids compatibility: For use with clean water and liquids without magnetic particles and without chemical incompatibility with brass, PPO and titanium

Nominal pressure at 20°C: 2,5 MPa (PN25)

Liquids temperature range: 5 to 100°C (Do not withstand water freezing inside pipe)

Paddle flow switches, reed switch contact, external brass body. Type: R1V



Ambient temperature range: 5 to 80°C

Ingress protection: IP55

Calibration tolerances: ±15% (on paddle operating force at end of paddle 1)

Electrical connection:

Standard:

IP54 connection box, with screw terminals connection block, M16×1.5 ISO cable gland

Options:

- Connection box with EN17530-803-A (DIN43650-A) connector

- Connection box with IEC947-5-2 M12×1 4 pins connector

Installation instructions:

- Check carefully the paddle orientation: The arrow on housing must be exactly parallel to the pipe

- A 5 mm minimum gap must be respected between end of the paddle and tube wall opposite to the fitting.

- We recommend the use of nozzles of length less than or equal to 18mm between the gasket seat and the inside of the tube and with an inner diameter greater than or equal to 13.5 mm, to avoid blocking of the pallet

Accessories: ¾" male PVC saddles for DN40 to DN100 (OD) PVC pipes, and other fittings: see section 8 of this catalogue.

Important notice: In the case of plastic pipes (PVC, PE), the DN (nominal diameter) corresponds to the **outside diameter** and wall thickness is variable depending on the application. This must be taken into account to avoid blocking the paddle. In the case of metal pipes, the inner diameter corresponds to the DN. Flow values data are for tubes whose **internal diameter** corresponds to DN.

Pipe mounting configurations

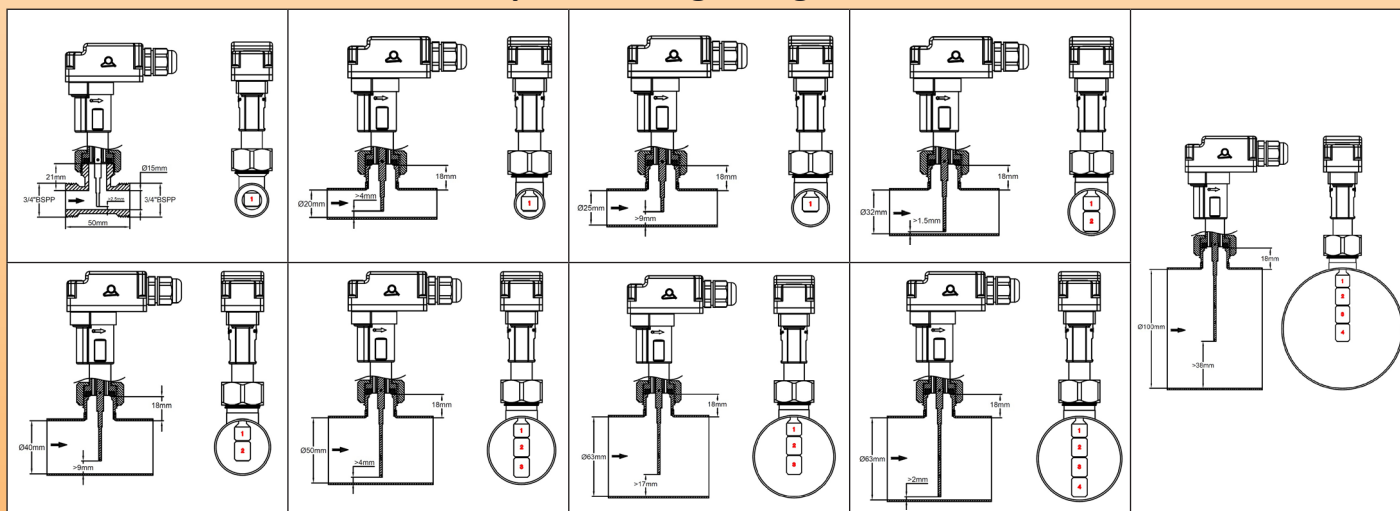

Average flow detection values (Liters/min)

Paddle length	Pipe ID (mm)															
	15		20		25		32		40		50		63		100	
	*Close	**Open	*Close	**Open	*Close	**Open	*Close	**Open	*Close	**Open	*Close	**Open	*Close	**Open	*Close	**Open
1-m	2,7	2,3	4,8	4,5	13	11	22	20	38	35	67	47	167	112	472	317
1-H	4,3	3,3	7,3	6,5	18	17	29	27	53	48	83	72	218	142	616	401
1-M	5,5	3,2	14	12	25	22	38	35	67	60	132	108	262	202	740	571
1+2-m									20	18	37	32	68	52	192	155
1+2-H									30	28	53	43	88	72	248	203
1+2-M									40	37	67	63	123	115	347	324
1~3-m											22	20	37	33	125	108
1~3-H											34	32	63	50	176	165
1~3-M											46	43	77	73	233	217
1~4-m													27	24	88	72
1~4-H													43	40	140	132
1~4-M													58	55	180	167

m= calibration at min span
H= calibration at Half span
M= calibration at Max span

* Close by flow rise (L/min) of contact open at no flow position
** Open by flow decrease (L/min) of contact open at no flow position. Average values for indication only. Standard tolerances ±15%

Because of permanent improvement of our products, drawings, descriptions, features used on these data sheets are for guidance only and can be modified without prior advice

Paddle flow switches, reed switch contact, external brass body. Type: R1V



Main references (With type A cleavable paddle)

Calibration (Calibration force $\pm 15\%$, measured at end of paddle N°1)	Electrical connection		
	Waterproof connection box with M16x1.5 cable gland	Waterproof connection box with 4 pins, M12x1 IEC947-5-2 connector	Waterproof connection box with DIN 43650-A Connector
Low span end: 3gr	R1V636680G35N00C	R1V636680G35N00L	R1V636680G35N00D
Middle span: 7gr	R1V676680G35N00C	R1V676680G35N00L	R1V676680G35N00D
High span end: 14gr	R1V6E6680G35N00C	R1V6E6680G35N00L	R1V6E6680G35N00D

Other paddles (Non cleavable models)

Paddle type B	Paddle type C	Paddle type D	Paddle type E
Replace 6680 in reference by 1234	Replace 6680 in reference by 1549	Replace 6680 in reference by 1564	Replace 6680 in reference by 1579

Consult us for flow detection values with these paddles. OEM paddles can be made on order (MOQ apply)

Because of permanent improvement of our products, drawings, descriptions, features used on these data sheets are for guidance only and can be modified without prior advice